

# BRICON

Little BRICON 1000 *NEW LOOK*



## User Guide

versie UK-20 of hoger



*The little BRICON is intended for the electronic timing of racing pigeons.  
The Little BRICON should only be used for the purpose that it is intended.  
Protect the little against water and extreme sunlight an temperatures.*

*Modifications reserved.*



## Index:

	Page
1. Installation.	
1.1. Foreword.	4
1.2. Unpacking the installation.	4
1.3. Assembly of the electronic timing system.	4
2. Connect the electronic timing system.	
2.1. Before you can clock.	5
2.2. Exploring the menu for the first time.	5
2.3. Set your language.	5
2.4. Programming the antennas.	6
2.5. Install the antennas.	7
2.6. Testing the antennas.	11
2.7. Connect and test the electronic observation system	11
3. Coupling the electronic chip ring to the national foot ring .	
3.1. Get started.	12
3.2. Browse linking table.	12
4. Clocking a training.	
4.1. Delete data from ETS.	13
4.2. Clocking a training.	13
5. Clocking a race.	
5.1. Deleting races.	14
5.2. Basketing a race.	14
5.3. Viewing races in the ETS.	14
5.4. Clocking during a race.	14
5.5. Set speed calculation (m/min).	15
6. Extra functions during clocking.	16
7. Race status.	16
8. Printing data from ETS.	16
9. Settings.	
9.1. Add clubs to the ETS.	22
9.2. Examine clubs in the ETS.	22
9.3. Deleting clubs.	22
9.4. Set number of printouts.	22
9.5. Set number of lines of the printout.	22
9.6. Set the clock.	22
9.7. Change password.	23
9.8 PC Connection.	23
10. Options.	
10.1. BRICON +.	23
10.2. Printer interface / Print Manager.	24
10.3. Modem / SMS interface.	24
10.4. Emergency battery.	24
10.5. Antenna buffers.	25
11. Short working method.	25
12. Problems and solutions.	25
13. Maintenance and service.	26
14. Overview menu.	27
15. Declaration of conformity.	28



## 1. Installation

### 1.1 Foreword.

Thank you for your trust and confidence in BRICON.  
This manual will give a detailed explanation of the functions of the little.  
BRICON wish you much enjoyment with your purchase.

### 1.2 Unpacking the instillation.

A little BRICON pack contains:

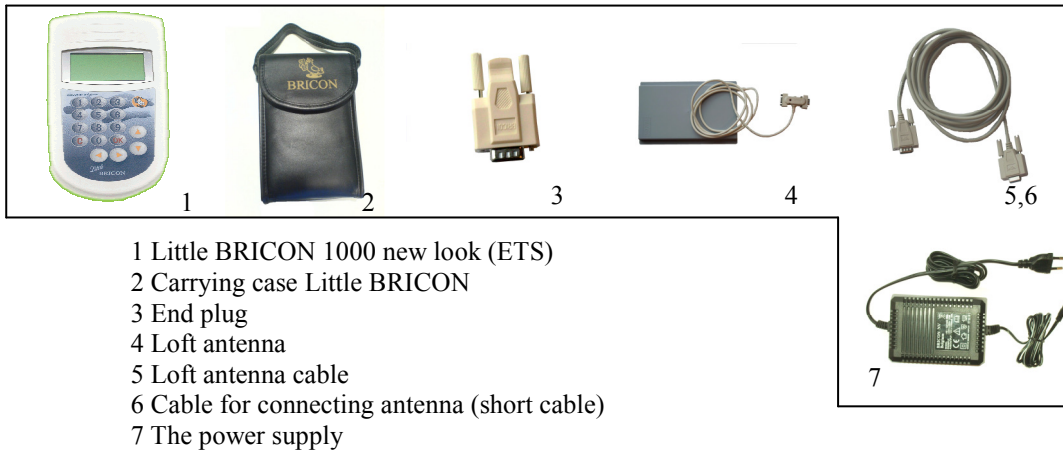

### 1.3. Assembly of the electronic timing system.

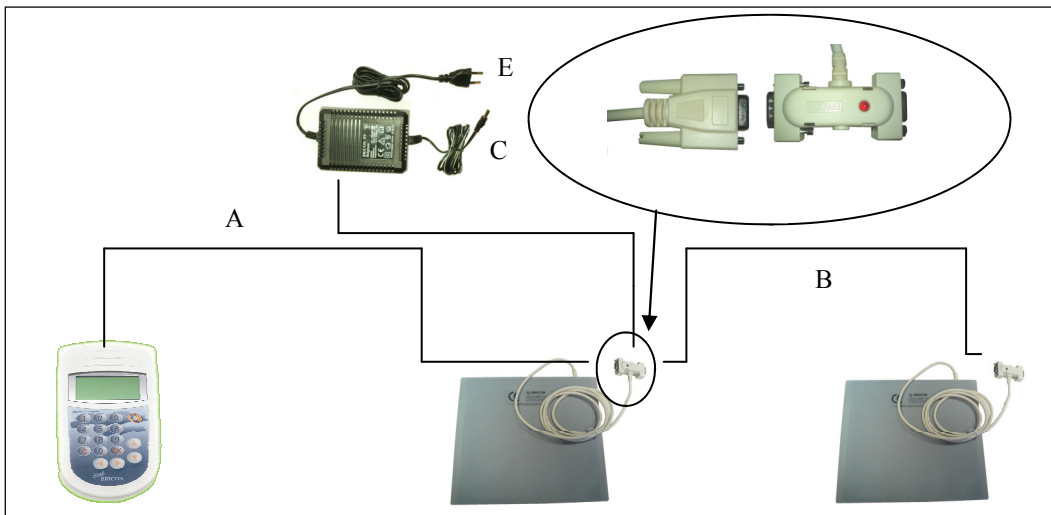





## 2. Assembly of the system

### 2.1. Before you can clock.

Before you can time pigeons, you must go through the following steps:

-After programming the antennas, the installation can then be completed by connecting the antennas to each other.

-The ring numbers of the birds can then be linked to the electronic chip rings (see 3.1).

### 2.2. Exploring the menu.

After connecting the clock to the antennas, you can plug the power supply into the Antenna connector(1), and the red power light will show(2)

After initialisation and if little BRICON detects one or more loft antennas and if there are pigeons in the clock, Little BRICON goes in to clocking mode.

**Attention ! In this guide appears beside the titles the number combination e.g. (C,3,1,4)  
If you press this combination you come more rapidly on the desired menu.**

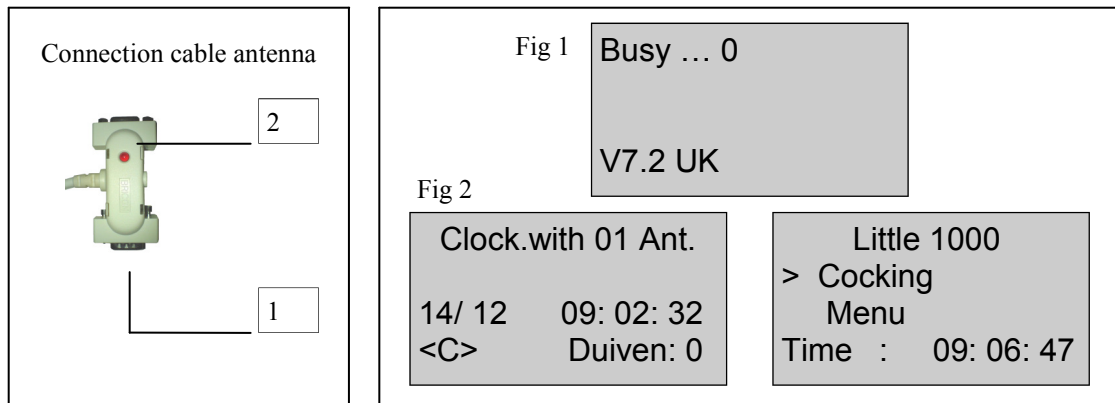

With the keys “▲” “▼” you can select a different line.

The selected line is marked with “>”. Press “OK” to confirm your choose.

Press “C” to cancel.

On top of the screen you see the name of the sub-menu. The number between the brackets indicates the number of sub-menu.

We see visual only 3 sub-menu but by pressing the ▼ we are able to go lower in the menu.

You can select also more rapidly the sub-menu by simply pressing the number on the numerical keyboard .

Please note: Some menu not apply. If you choose these menu, the text “component permitted” appears on the screen.

### 2.3. Set your language (C,2,4,5,1)

Press “2” “Menu”, Press “4” “Settings” and press “5” for “Other”.

Choose option “1” or press “OK” .

With the arrow “▲” and “▼” select the language of your choice. Press “OK”.

It is also possible to press the number of your choice on the keyboard (Ex. “1” English).

The ETS switches to your selected language.

Press “C” to return to the previous screen.



## 2.4 Programming the antennas(C,2,4,3,1).

Before you can use the clocking system, you must program or number the antennas, giving each antenna on your system a different number. the programming is only necessary at the first time . Generally the antennae have been already pre-programmed by BRICON.

The number is then written on the back of the antenna.

If there is no number you can program the antenna with the little.

Connect the antenna on the little for programming, connect the power supply. After initialisation press “C”. Press “▼” and select “menu”, press “OK”. Select 4 Settings , 3 Antennas and 1 Prog.anten. Type antenna number 1 -> 16. use “◀” and “▶” to change position

**Attention ! Each antenna in the system must be given a different number from 1 to 16.**

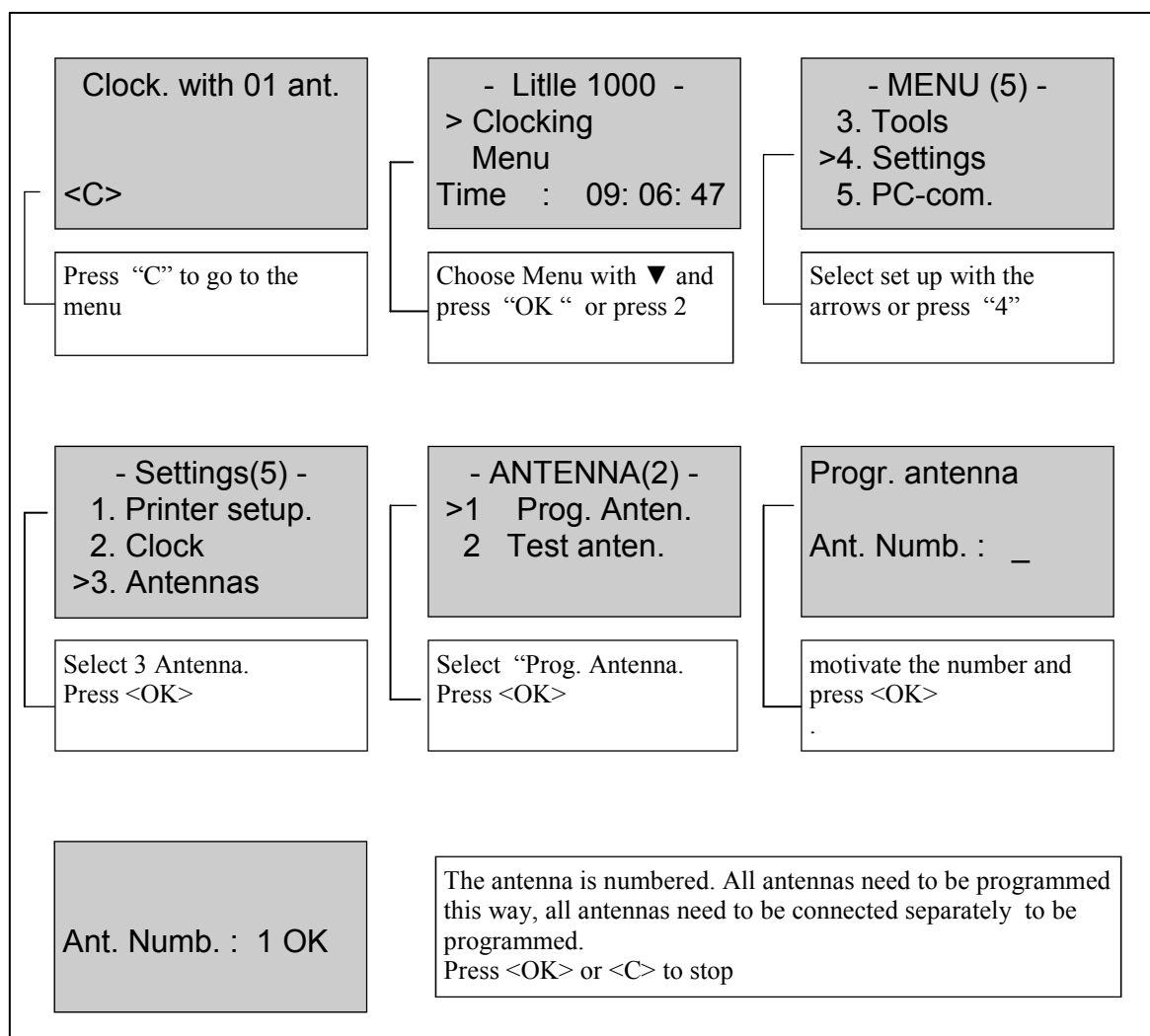



## **.5. Installing the antennas.**

The antennas are connected to each other in line using a connection cable. Each antenna pad has an integral cable attached of 1.80 m. The Speedy clock should be connected to the antennas. An end plug should be connected to the final antenna in circumstances where more than four antenna pads are connected together in the system.

As the signal will pass through most materials, it is possible to install the antenna either above or beneath the entrance board of the loft (with a recommended thickness of no more than 15mm). The entrance hole to the loft must be 2 cm smaller than the width of the antenna pad. Bricon produces a range of antenna pads to meet the needs of any loft, supplying pads in widths of 14 cm, 28 cm, 50 cm and 70 cm. The BRICON antenna will record over the entire width of the pad and therefore tunnels are not needed. It is advisable however to slow down the pigeons before they enter onto the antenna. It is advisable to install the antenna pads at least 1 metre away from each other. Within the surrounds of the antenna pad, metal is not allowed (either under and above the antenna).

### **Antenna under the dropping board and before the bob wires**

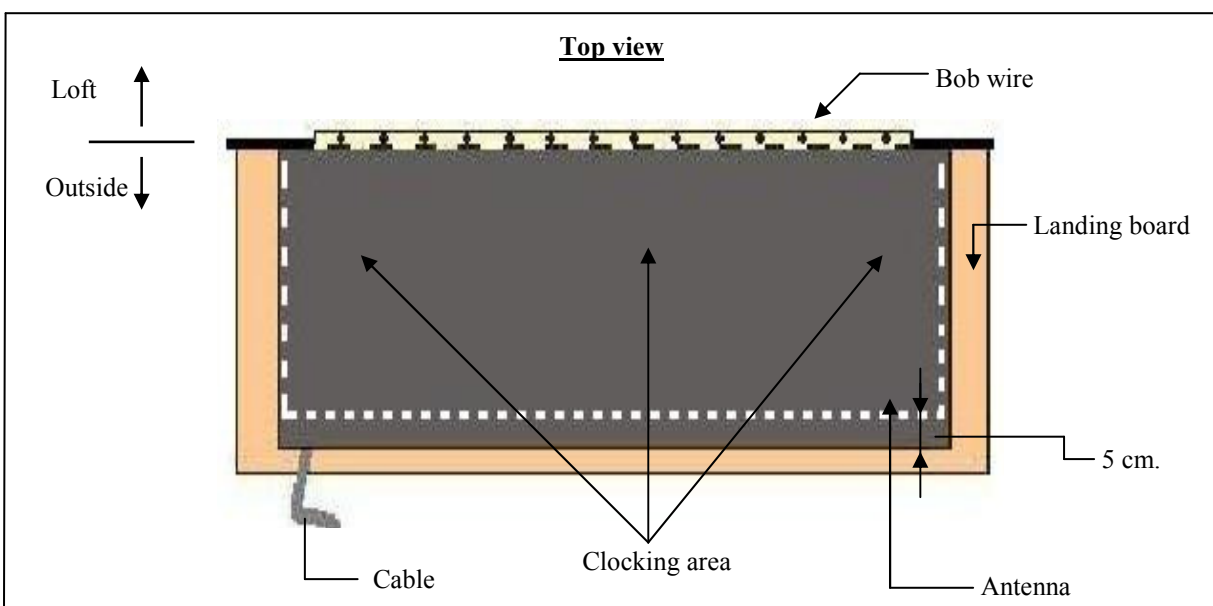
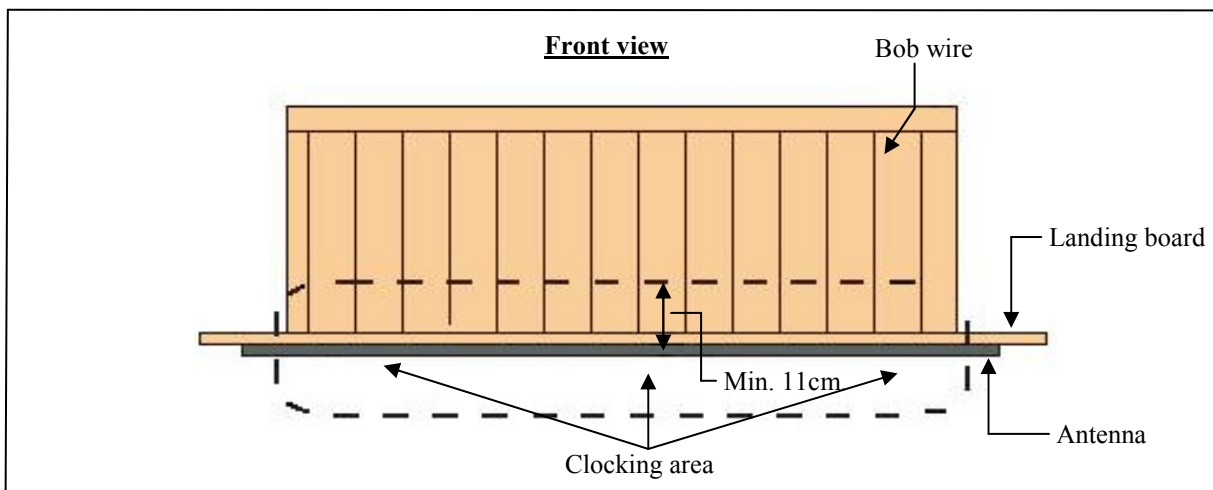

**Attention ! Install the antenna with the cable outside**



**Antenna pad inside of the entrance and behind the bob wire**

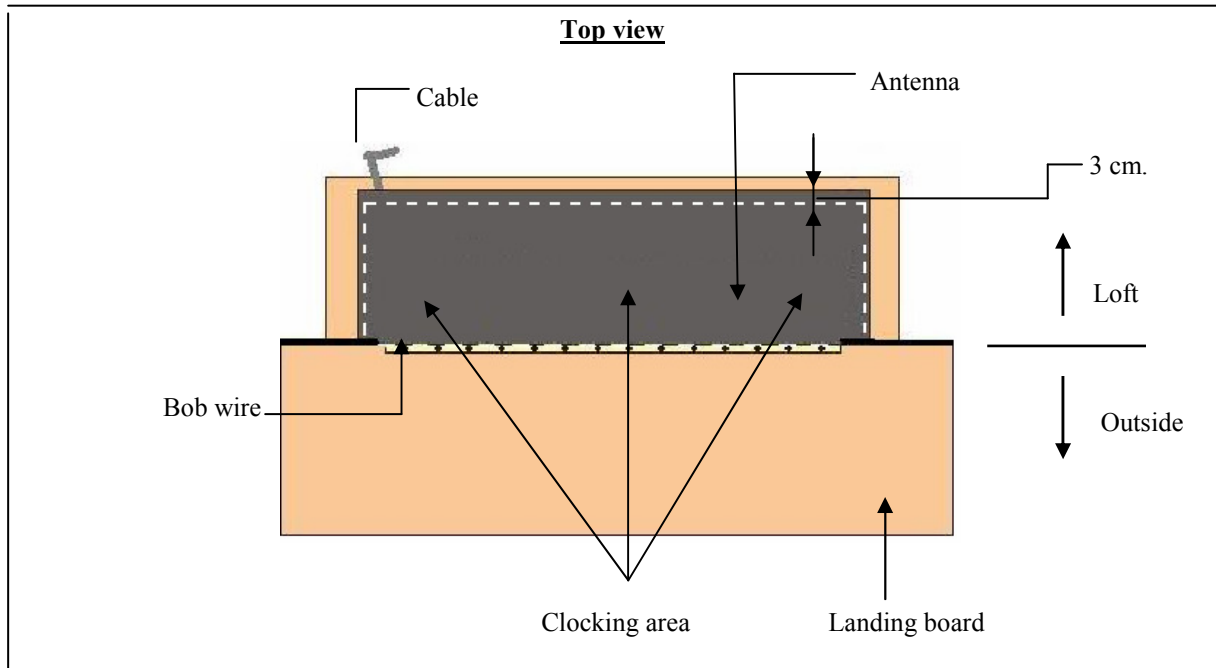

***Attention ! Install the antenna with the cable outside***

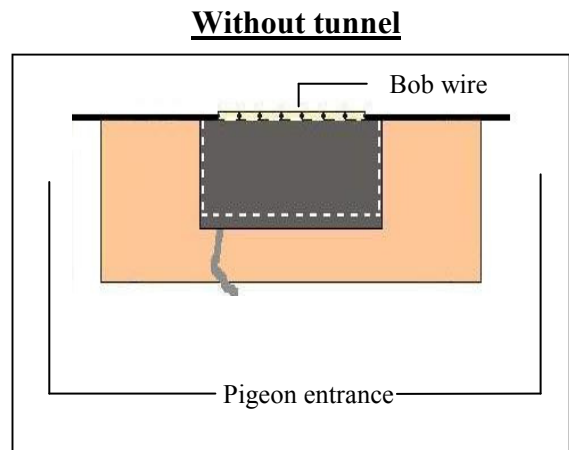
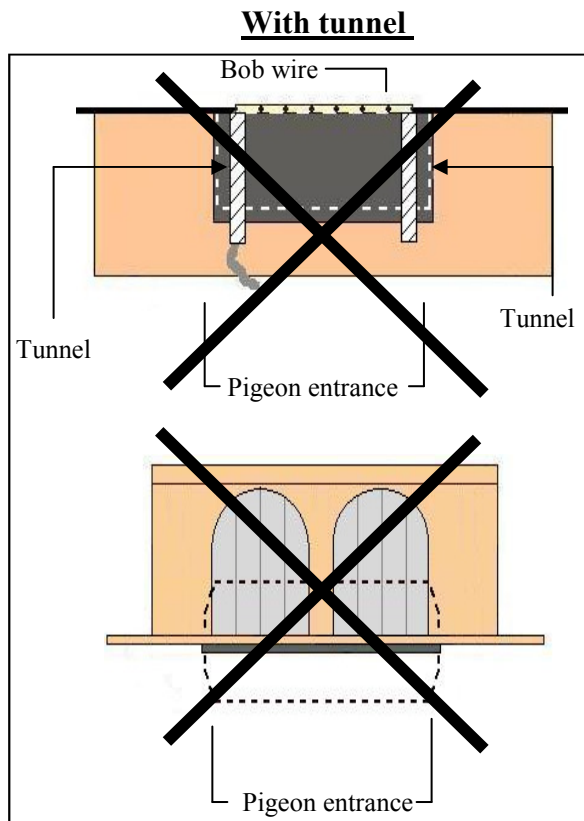

With BRICON antenna pads a tunnel is not necessary.  
In the most cases tunnels prove to be a big disadvantage, with pigeons compressed into the entrance with jams occurring as a consequence





## Clocking many pigeon on one antenna

If it is necessary to clock many pigeons on one antenna on the same time. It is advised to install the antenna as following.

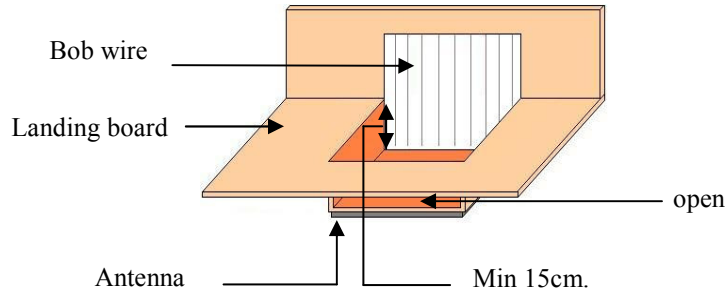

On the landing board, you can build an area which is lower. The antenna is installed under the area.

The pigeons come one by one, and not at the same time on the antenna. The registration is much better this way.

An other manner with the same result is making a higher area .

The higher area is also needed if you have a landing board in zinc . This because metal disturbs the antenna.

The higher area is min 10cm higher then the base.

The board max 15mm thick.

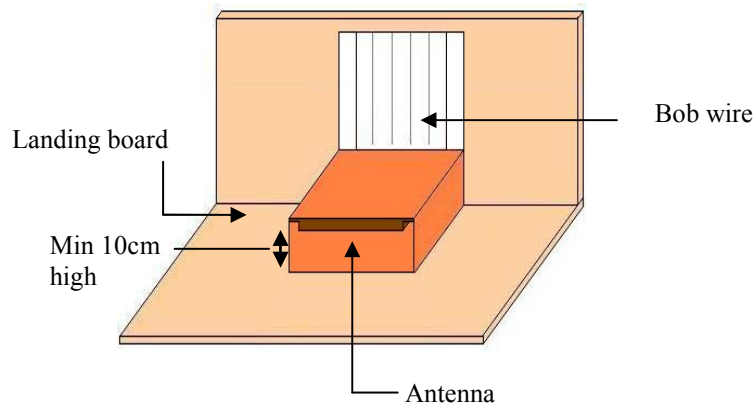

You may find it convenient to buy a modified entrance.

If you choose this solution we advise the Futura (designed by BRICON and produced by Demster and Haspeslagh).



Use the right power supply. Make sure that the total electricity consumption of the network does not exceed the maximum capacity of the power supply.

Calculate the total electricity consumption as following:

	number		
Electronic clock		x 110mA	=
1-field antenna		x 230mA	=
2-field antenna		x 350mA	=
4-field antenna		x 570mA	=
6-field antenna		x 790mA	=
		Total	=

Example :

You use one clock (ETS).

You need 3 antennas with 2 fields.

You get the next result:

	number		
Electronic clock (ETS)	1	x 110mA	= 110mA
1-field antenna	0	x 230mA	= 0
2-field antenna	3	x 350mA	= 1050mA
4-field antenna	0	x 570mA	= 0
6-field antenna	0	x 790mA	= 0
		Total	= 1216mA

The total of electricity consumption is 1216mA. We can use a standard power supply from 1500mA. If the electricity consumption is higher use a power supply with higher capacity. Each component consumes a part of the energy, therefore we have to spread the power cables so that each component on its own has enough energy to function perfectly .  
If two ore more power supplies are needed, you must use an interruption cable.

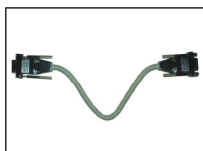

**For the calculation of the electricity consumption and the number of power cables in larger networks we recommend to ask the advice of your salesman.**



## 2.6. Testing the antennas(C,2,4,3,2).

After start up press “C” and “3” “Menu”, press 4” “Settings”, “3” “Antennas”, “2” Test anten. You see on the display “Test with 02 Ant”. If an antenna is not shown on the display, it will not detect properly. Double-check the connections and the functioning of the antenna. (maybe you need to re-program the antenna (s).

Hold a chip ring on the antennas. On the display you see the chip-id.

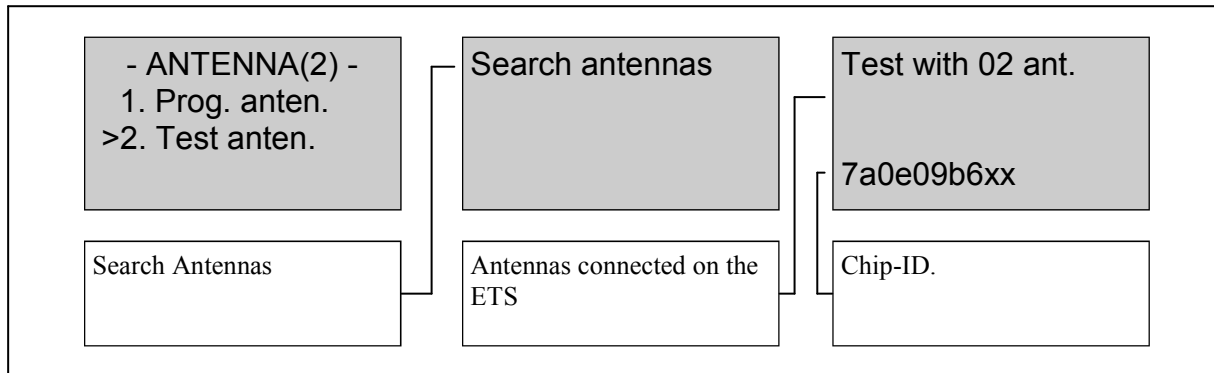

## 2.7. Assembly of the electronic timing system.

After programming and installing the antennas in the loft, the power supply can be connected to the system.

Connect the Little BRICON clock at the beginning or end of the installation.

All the lights on the antenna cables will then become red.

When this doesn't occur there is a problem with the power supply or the cable connections.

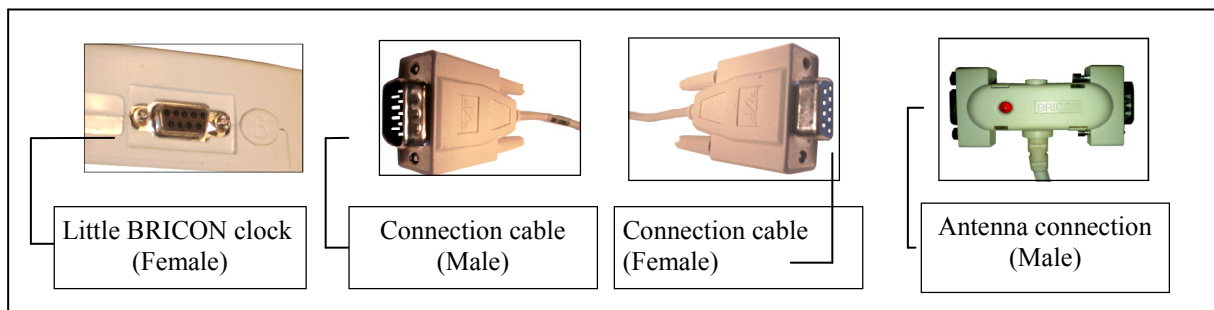



### 3. Coupling the electronic chip ring to the national foot ring

#### 3.1. Coupling , how do I start(C,2,3,1,1).

*The coupling of the electronic chip ring to the national foot ring is always done in the clubs.*

An advantage of the BRICON system is that the fancier can pre-couple his pigeons at home. When this pre-coupling is done he can already start using the system for training sessions. To take part in official races, the pre-coupled rings are transferred to the club computer and sealed. Once this is done, the system may be used on official races. To pre-couple the rings, next steps should be followed. Connect the ETS in the network as described.

Connect the clock to the antennas and the power supply.

After initialisation you see on the screen "Clock. with 01 Ant". Then press "C"

Press the "▼" key on the keyboard of the ETS until "Menu" is selected.

Now Press "OK". On the new display 5 submenus appear (The number between brackets indicates the number of submenus). We only see 3 submenus. By pressing "▼", or by entering the figure before the submenu on the ETS, a submenu can be selected. Select Tools(3) and press "OK". Select "Linking" and press "OK".

Select "ADD" and "OK" Put the chip ring on the pigeon and hold the chip ring above the antenna. Give the country code. With the vertical arrows you can choose a character, with the horizontal arrows you can move from the left to the right. Maximum 4 characters are allowed. Enter the Year. Maximum 2 numbers are allowed, use the numbers on the keyboard of the ETS. Use the 2 last numbers of the year ex. 2001,01)

Give the ring number, maximum 9 characters are allowed. With the horizontal arrows you can move from the left to the right. Press "OK" and put the colour in. Maximum 4 characters are allowed.

#### 3.2. Browse linking table(C,2,2,4,2)

With this function you can browse through the database of pigeon linking, and delete any ring numbers not required.

Choose "2" (Menu). On the next screen choose "2"(Edit) , Press 4 "pigeons. Press "2" for "Browse". With "▼" and "▲" you can move backwards or forwards through the list.

Press "C" to quit.

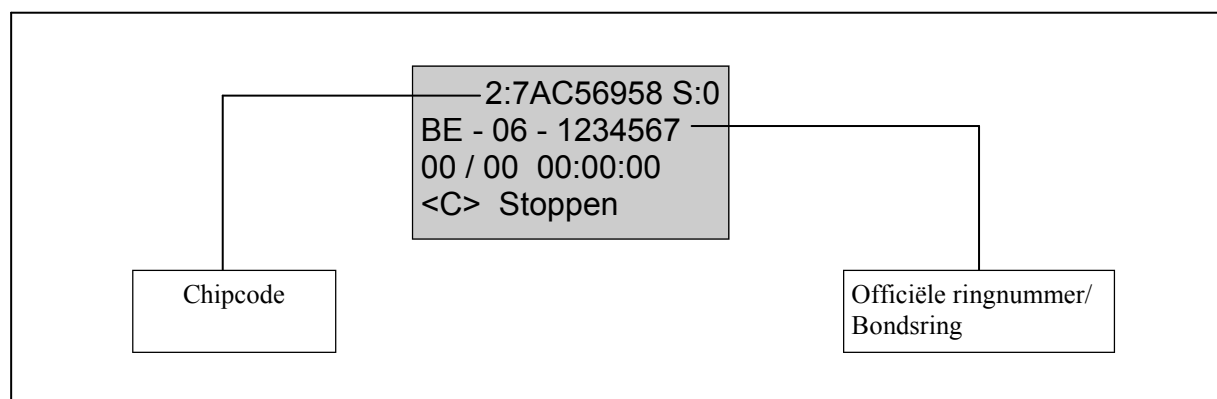





## 4. Clocking a training

### 4.1. Delete data from the ETS(C,2,2,2)

To delete training and released data of a race, press in the start-up menu “menu(2)”, “Edit(2) and delete(2). Enter your password. Standard 0000(four times zero). This password can be changed (see change password).

### 4.2 Clocking a training.

Connect the antennas to the ETS (see page 5). If there is no race the clock automatically goes to ‘Training mode’. The display shows how many antennas are used to clock.

*If this number does not correspond to the real number of antennas you need to reset the antennas (see testing the antennas). Possibly the antennas need to be reprogrammed (see programming the antennas)*



Clock. with 01 ant

While clocking, the display shows the foot number, the place of arrival, the day and hour of arrival, the type of race and the antenna on which the clocking was registered. Using “▼” and “▲” you can scroll in the list of clocked pigeons. This is possible during clocking.

**The clocked pigeons stay in the memory of the ETS until they will be deleted manually (see delete data from ETS). A pigeon can be clocked only once, to clock the pigeon again you need to delete his data !**

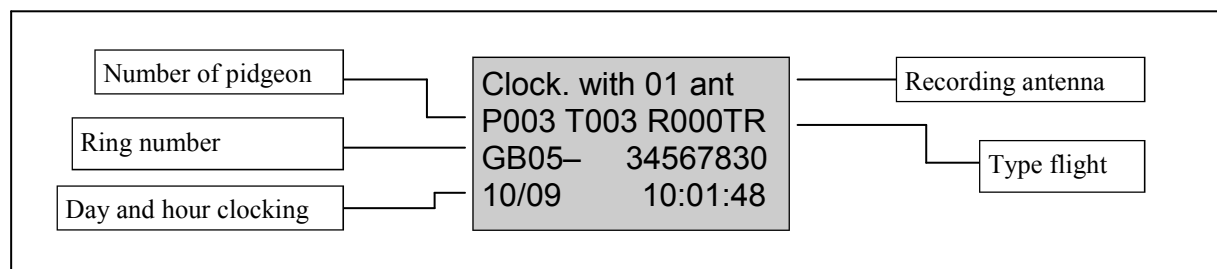



## 5. Clocking a race

### 5.1. Deleting races(C,2,2).

**Attention: Before basketing all clockings must be deleted.**

In the menu choose Edit(2) and select delete(2). Enter your password. Standard 0000(four times zero). This password can be changed (see change password). The clockings of active races or unclosed races can not be deleted.

### 5.2. Basketing a race.

When a fancier is basketing a race, the ETS has to be taken with the pigeons to the club. In the club the ETS has to be connected to the CLUB SYSTEM. During basketing the pigeons are registered in the ETS for the specific race.

A list of information concerning a race can always be printed from the ETS.

**Attention : all released data need to be deleted before basketing can start (see delete data from ETS)**

### 5.3. Viewing races in the ETS(C,2,2,5).

To examine the basketed pigeons we must leave the clocking mode. This is possible by pressing 5 seconds on "OK" while the clock start up. If the clock is connected without antennae there is also access to the menu. Choose in the menu 2 (menu). Select race (1) and press "OK". Choose "1" (basketing). On the display appear the basketed races with the number of the Club. By pressing on the vertical dart ▲ and ▼ you are able to examine the flights.

### 5.4. Clocking during a race

After connecting the antenna and the power supply, the clock goes automatic to clocking mode. When a pigeon is clocked, the display shows the number, the pigeon clocked on the total number of and also the day and the hour of the clocking.

Furthermore you can find the type flight and with which antenna the clocking happened.

By using the vertical darts ▼ and ▲ you can overflow in the list of all clocked pigeons (you can do this during the observation).

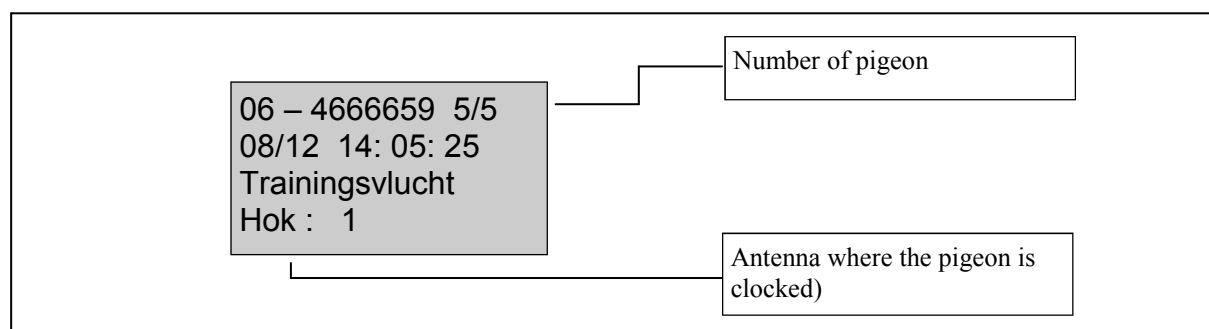
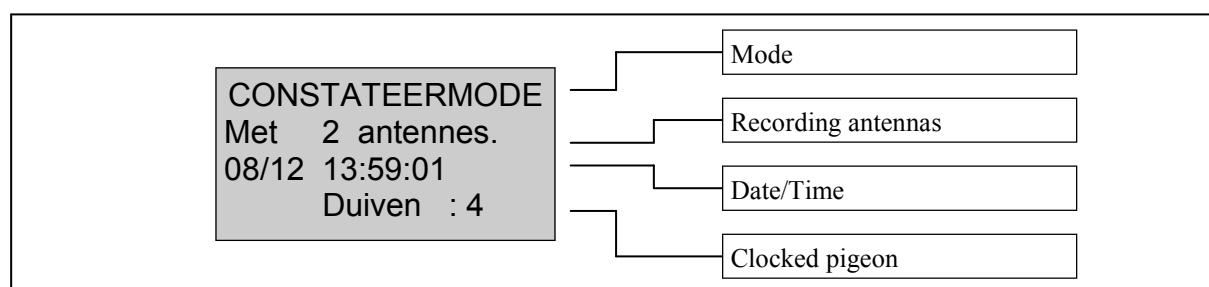



### 5.5. Set speed calculation(m/min)(C,2,4,4,2)

In the start– menu select menu and press “OK”  
On the new display 5 submenus appear (the number between brackets indicates the number of submenus). We only see 3 submenu’s. by pressing the “▼” key or simply through pressing the number of the submenu on the keyboard of the ETS, the submenu will be selected.  
Select “Settings”(4)

With the active flights (basket) it is possible to put in the distance between the loft and the racing place. With the distance the start and end time , the clock can calculate wat the what the average speed is. Only displayed on the clock, not on the print out.  
Go to main menu (option3) and choose M/min (4) Select the flight, and put in the distance.  
It is possible to do that with the numbers on the keyboard.  
The first 4 positions are the kilometres en the other 3 positions the meters.

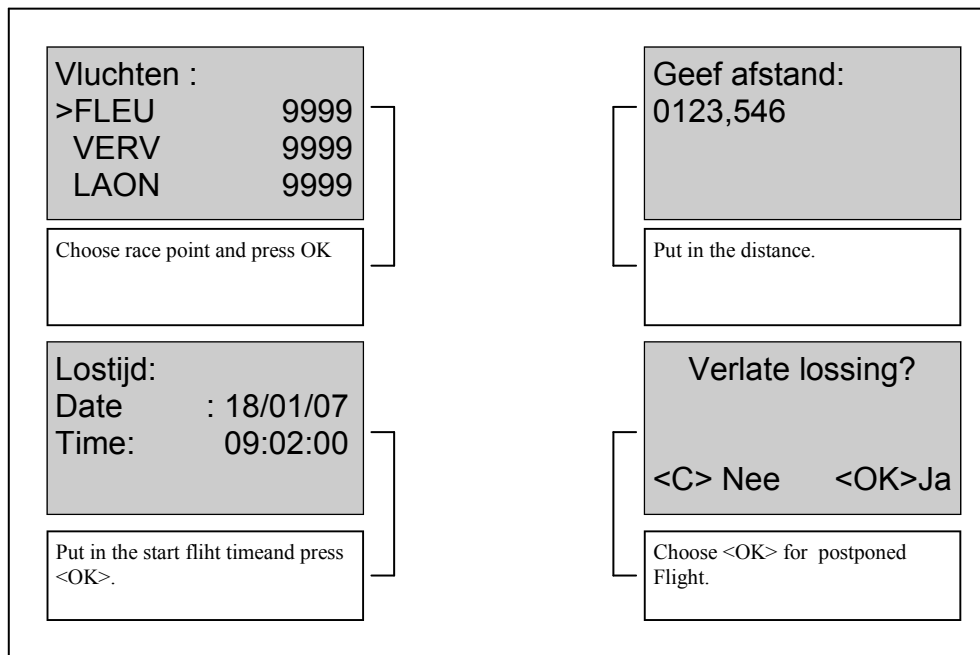



## **6. Extra functions during clocking.**

During clocking you can see different data.

Button 1 : shows all connected antennas.

Button 2 : Activate the storing module.

## **7. Race status (C,2,1,5).**

On the display you see all the races in the ETS.

The name of the race and the date.

With the button “▲” and “▼” is it possible to scroll.

After finishes the race we recommend to delete the races.

## **8. Printing data from ETS.**

From all the data in the ETS you can make a print-out.

In that case you need a optional printer interface and a dos compatible printer.

It is also possible to use Print Manager USB

### **8.1. Several prints(C,2,2,2,3)**

8 Submenus will appear on the display. Choose what kind of data you want to print

1. Overview
2. Clocking.
3. Training
4. Betting's
5. Linking
6. Races
7. Nomination
8. Clubs





### 8.1.1. Overview(C,3,2,3,1)

Prints out a complete overview of what is in the ETS.

#### The overview list in detail.

```

-----
                          Overview list
-----
Date : 24/07/00 (1)
Member      : XXXX XXXX (2)
              Name      : XXXX XX (3)
X-Coordinate : XXXXXX (4)
              Y-Coordinate : XXXXXX (4)
Print date   : XX XX XX XX:XX:XX (1)
-----
Check :
      Basketing(5)          Sync.(6)
      Mother clock         Timer Diff.. Mother clock      Timer
Nb  Race 230600 192639 192639 +000 000000 000000 000000 +000 +000
 2  CREP 250600 162005 162005 +000 250600 140523 140524 +001 +000
 3  MOMI 250600 204502 204503 +001 000000 000000 000000 +000 +000
-----
      (5.1) ----- (5.2) ----- (5.3) ----- (5.4) ----- (6.1) ----- (6.2) ----- (6.3) ----- (6.4) ----- (6.5) -----
List pigeons : (7)
Nr. El.-ring IDring Sex Race Des Date Time *Eval
 1 7A589624D BE-00-0003141309 V BOUR 1 23/06/00 19:27:05 2
 2 7A47C25E2 BE-00-0003141312 BOUR 2 23/06/00 19:28:24 1
 3 7A33FF126 BE-00-0003141363 BOUR 3 23/06/00 19:29:33 1
 4 7A1F471D2 BE-00-0003141304 BOUR 4 23/06/00 19:29:59 1
 5 7A44F475E BE-00-0003141345 CREP 1 25/06/00 16:23:05 1
 6 7A12E12E1 BE-00-0003141361 CREP 2 25/06/00 16:25:00 2
 7 7A14FF154 BE-00-0003141396 V MOMI 1 25/06/00 20:46:19 2
 8 7A1A584D6 BE-00-0003141401 MOMI 2 25/06/00 20:46:55 2
-----
      (7.1) ----- (7.2) ----- (7.3) ----- (7.4) ----- (7.5) ----- (7.6) ----- (7.7) -----
*Legend (8)
! : Secret code not correct 0 : Reset. 1 : Clocked. 2 : Basketed
3 : Designated. 4 : Cl. w. Module 5 : Training
-----
Signature
(9) .....

-----
Ver : US-08 (10) - Little 1000 -
Address : XXX XX XXXX XXXXXX (12) Serialn: BB129B (11)
-----

```



### 8.1.2. Training clocking list(C,3,2,3,2)

Print the training results from the ETS.

---

List of the clocked pigeons.

---

Race nr : \_\_\_\_\_ Date : XX/XX/XX (1) RACE: Training (10)  
Member : XXXX XXXX (2) Name : XXXXX XX (3)  
X-Coordinate : XXXXXX (4) Y-Coordinate : XXXXXX (4)  
Print date : XX/XX/XX XX:XX:XX (5)

---

Nr. Pigeon	Color	Date	Time
1 BE-00-0003141312	BB	25/06/00	13:36:14
2 BE-00-0003141363	BBWF	25/06/00	13:41:22
3 BE-00-0003141315	PALE	25/06/00	13:49:25
4 BE-00-0003141362	RED	25/06/00	13:49:25
(6) (7)	(8.1)	(8)	(9)

(1) date of print out. (2) member number.  
(3) name of the fancier. (4) coordinates of the loft of the fancier.  
(5) date and time of the print out. (6) number.  
(7) official ring of the federation. (8) date of clocking.  
(8.1) color (9) time of clocking.  
(10) sort of race = training. (11) signature(s).  
(12) software version of the electronic clock (EC). (13) address of the fancier.  
(14) serial number of the electronic clock (EC).

---

Signature  
(11) .....

---

- Little 1000 -

Ver : US-08 (12) Serialn: BB129B  
Address : XXX XX XXXX XXXXXX(13) (14)

### 8.1.3. Clockings(C,3,2,3,3)

Print the race results from the ETS, choose the race and press "OK"

---

List of the clocked pigeons.

---

Race nr : \_\_\_\_\_ Date : XX/XX/XX (1) RACE: XXXX (10)  
Member : XXXX XXXX (2) NAME : XXXX XX (3)  
X-Coordinate : XXXXXX (4) Y-Coordinate : XXXXXX (4)  
Print date : XX/XX/XX XX:XX:XX (5)

---

Nr. Pigeon	Color	Date	Time	Race	*Eval
1 BE-00-0003141312	BBWF	25/06/00	13:36:14	BOUR	1
2 BE-00-0003141363	PALE	25/06/00	13:41:22	BOUR	1
3 BE-00-0003141304	RED	25/06/00	13:49:25	BOUR	1
(6) (7)	(7.1)	(8)	(9)	(10)	(11)

(1) date of print out. (2) member number.  
(3) name of the fancier. (4) coordinates of the loft of the fancier.  
(5) date and time of the print out. (6) number.  
(7) official ring of the federation. (7.1) color of the pigeon.  
(8) date of clocking. (9) time of clocking.  
(10) race. (11) evaluatie, getekende en reeks.  
(12) signature(s). (13) software version of the electronic clock (EC).  
(14) address of the fancier. (15) serial number of the electronic clock (EC).

---

Signature  
(12) .....

---

- Little 1000 -

Ver: US-08 (13) Serialn: BB129B  
Address : XXX XX XXXX XXXXXX(14) (15)







### 8.1.6. Races(C,3,2,3,6)

Prints a list of races in the clock.

---

Races

---

Date : XX/XX/XX(1)

Member : XXXX XXXX (2)                      Name : XXXX XX (3)  
X-Coordinate : XXXXXX (4)                  Y- Coordinate : XXXXXX (4)  
Print date : XX/XX/XX XX:XX:XX (5)

---

Nr. Race	Nr. Race	Nr. Race	Nr. Race
1 ANGOULEME	2 ARGENTON	3 ARRAS	4 BARCELONA
5 BEZIERS	6 BLOIS	7 BOURGES	8 BORDEAUX
9 BRIVE	10 CAHORS	11 CASTRES	12 CHATEAUROUX
13 CHARTRES	14 CLERMONT	15 COGNAC	16 CREPY
17 CORBEIL	18 DAX	19 DOURDAN	20 ETAMPES
21 GEURET	22 LAON	23 LA SOUTERRAI	24 LA FERTE
25 LIBOURNE	26 LIMOGES	27 MARNE LA VAL	28 MARSEILLE
29 MOMIGNIES	30 MONTAUBAN	31 MELUN	32 NOYON
33 ORLEANS	34 PAU	35 PERIGUEIX	36 PERPIGNAN
37 PITHIVIERS	38 POITIERS	39 PONT	40 RIEMS
41 RUFFEC	42 ROYAN	43 SALBRIS	44 SENS
45 SOISSONS	46 SOUILLAC	47 ST-DENIS	48 ST-VINCENT
49 SAN SEBASTIAN	50 TOURS	51 TOURY	52 VIERZON
53 QUIEVRAIN			
(6) (7)	(6) (7)	(6) (7)	(6) (7)

- (1) date of print out .
- (2) member number.
- (3) name of the fancier.
- (4) coordinates of the loft of the fancier.
- (5) date and time of the print out.
- (6) number .
- (7) race.
- (8) signature(s).
- (9) software version of the electronic clock (EC).
- (10) address of the fancier.
- (11) serial number of the electronic clock (EC).

---

Signature  
(8) .....

---

- Little 1000 -

Ver: US-08(9)  
Address : XXX XX  
Pagina 1

XXXX XXXXXX(10)

Serial: BB129B  
(11)





### 8.1.7. The list of designated pigeons in detail(C,3,2,3,7).

Prints a list of all designated pigeons.

#### List of designated pigeons

Race nr : \_\_\_\_\_ Date : XX/XX/XX(1) RACE: XXXX (10)  
Member : XXXX XXXX (2) Name : XXXX XX (3)  
X-Coordinate : XXXXXX (4) y-Coordinate : XXXXXX (4)  
Print date : XX/XX/XX XX:XX:XX (5)

Nr.	El.-ring	ID ring	Color	Des
1	7A589624D	BE-00-0003141309	BBWF	1
2	7A33FF126	BE-00-0003141363	BB	2
3	7A44F475E	BE-99-0003235614	WHIT	3
4	7A14FF154	BE-99-0003235688	GRIZ	4
5	7A24FD122	BE-97-0003021501	PALE	5
6	7A14ED133	BE-97-0003021516	RED	6
(6)	(7)	(8)	(8.1)	(9)

- (1) date of print out . (2) member number.  
(3) name of the fancier. (4) coordinates of the loft of the fancier.  
(5) date and time of the print out. (6) number.  
(7) code of the chip ring (electronic ring). (8) official ring of the federation.  
(8.1) color of the pigeon (9) designation.  
(10) race. (11) signature(s).  
(12) software version of the electronic clock (EC). (13) address of the fancier.  
(14) serial number of the electronic clock (EC).

Handtekening Liefhebber Controlecommissie Klokcommissie  
(11) .....

- Little 1000 -

Versie : BE-18(12) Serienr: LBKC553D  
Adres : Europark Oost 15C 9111 Sint-Niklaas(13) (14)  
Pagina 1

### 8.1.8. Basketing list

#### Basketing list

Race nr. : \_\_\_\_\_ Date : XX/XX/XX(1) RACE: XXXXXX (9)  
Member : XXXX XXXX (2) Name : XXXX XX (3)  
X- Coordinate : XXXXXX (4) Y- Coordinate : XXXXXX (4)  
Print date: XX/XX/XX XX:XX:XX (5)  
Strike IN: XX/XX/XX XX:XX:XX (6)

Basketed : X (7) (8) Club :

DES	ID number	Color	Electr. Controle	Day	Bask. Time	1	2	3	4	5
1	NL-00-3141399	BBWF	7A58AF47	5/06/00	14:03:54					
2	NL-00-3141400	PALE	7A12E1A2	5/06/00	14:04:42					
3	NL-00-3141391	BB	7AE125A4	5/06/00	14:05:15					
(10)	(11)	(11.1)	(12)	(13)	(14)					(17)

- (1) date of the print out. (2) member number.  
(3) name of the fancier (4) coordinates of the loft of the fancier.  
(5) date and time of print out (6) date and time of read  
(7) number of pigeons basketed. (8) club where pigeons are basketed.  
(9) race (10) designation of the pigeon.  
(11) official ring of the federation. (11.1) color of the pigeon  
(12) code of the chip ring (electronic ring). (13) day and time of basketing.  
(14) zone for remarks. (15) signature(s).  
(16) software version of the electronic clock (EC). (17) address of the fancier.  
(18) serial number of the electronic clock (EC).

Signature  
(15) .....

- Little 1000 -

Vers: US-08(16) Serialn: BB129B  
Address : XXX XX XXXX XXXXXX(17) (18)





## **9. Settings**

### **9.1. Add clubs to the ETS(C,3,2,5,1).**

In the menu(3) setting (2) , choose clubs(5).  
Input the RPRA-number of the new club.  
This number have four characters  
Press “OK” , now you can input the name of the club..  
With “▼” and “▲” you can pass through the alphabet with “◀” and “▶” you can go to the next position  
Press “OK” to confirm.

### **9.2. Examine clubs in the ETS(C,3,2,5,2).**

In the menu(3) choose settings(2) than clubs(5) and view(2).  
On the screen you see the club-ID and the name.  
With “▲” and “▼” you can select an item in the list..

### **9.3. Deleting clubs (C,3,2,5,3).**

In the menu(3), settings(2), clubs(5) and delete(3).  
On the screen you see the club-ID whit the name.  
With “▲” and “▼” you can select in the list. Press “OK”.  
Press “OK” again to confirm the deleting.

### **9.4. Set number of printouts (C,2,4,1,1).**

In the menu(2), Settings(4), printer setup(1) select copies( 1)  
And press “OK”. Press “OK” again. Change the number of pages.  
Confirm the change. The new number is set.

### **9.5. Set number of lines of the printout(C,3,4,1,2).**

In the menu(3), settings(4), print setup(1) number of lines.  
Select(2and confirm with “OK”. Press “OK” again to change the number of lines.  
followed bij “OK” to confirm.

### **9.6. Set the clock(C,3,4,2,1).**

The timer of the ETS is synchronised while basketing. The timer can also be set manually. This may be useful after a long time of inactivity of the ETS (winter period). Make sure all data is deleted. For security reasons there may be no basketed races in the ETS, If there are it is impossible to change the time settings.  
In the menu(3), settings(4) choose clock(2) and settings(1).  
You see the actual date and time on the display. To change press “OK”.  
Now you can set the exact time and date. De day is a number between 1 and 31,  
The month between 1 and 12 and the two last characters of the year (2006 is 06). Input a number between 0 and 23 for the hour, and between 0 en 59 for the minutes and seconds. Press “OK” and the time starts running.



### 9.7. Chance password(C,3,4,5,2).

You need the password for deleting the data from the ETS (see delete data).  
Standard is the password 0000 (four zeros)  
Throughout the menu (3), settings(4), other(5) and select password(2).  
Press "OK" for changing the password. First type the old password,  
Standard 0000( 4 times 0).  
Put in the new password ( 4 digits) and retype the new password .  
Press "OK", the password is changed.

### 9.8. PC Connection

Niet van toepassing in België

## 10. Options

### 10.1 BRICON+

#### 10.1.1 Function :

De BRICON + is a second clock used for clock arriving pigeons while you go with your Bricon main clock to the club for basketing or read out.  
There are 3 models, for the speedy, Little Bricon new look and one for the older models.  
The working principle is the same only the form is different.  
The BRICON + is connected between the head clock and the antennas. It is also possible to use a split cable

#### 10.1.2 Basketing, how and when with BRICON + :

Bricon+ is a complete clock with Real Time Clock and memory to store 200 pigeons.  
You basket your pigeons on your regular clock (Speedy or Little).  
The clock is synchronised on the club antenna from the radio controlled clock.  
You can even basket a second and third race if you want, it doesn't change anything.  
You don't need your Bricon+ for basketing.  
At home you connect your Speedy/Little to your antenna's and wait for the pigeons to come ...  
When you need to disconnect your clock to go basketing or for a read out and pigeons still have to come home, then you need your Bricon+.  
How to proceed ?- disconnect your regular clock

- connect your Bricon+,
- Bricon+ starts beeping and is asking for synchronisation,
- Connect your regular clock to the Bricon+, the + gets its synchronisation from your regular clock. Synchronisation is only possible if the regular clock has an active race on board, because only then the time in the regular clock is valid (prevent cheating)
- after synchronisation, disconnect your regular clock and Bricon+ shall clock all pigeons that come home when the regular clock is gone.
- when you come back with your regular clock, connect the clock to Bricon+ and all clocked pigeons are transferred. Bricon+ clocks every pigeon coming home (race and training) when it's properly synchronised. Bricon+ clocks all pigeons walking over the antenna's even the stray birds with a chip ring. While updating the regular clock with the data from + the clock makes the selection which race, training or stray bird. You don't need to take Bricon+ for basketing nor for read out. You don't have to anything with Bricon+, just plug it in and synchronise (connect to the regular clock).



### 10.1.3 BRICON+ with display

The bricon + is from 2006 equipped with a display. working method is the same, but now it is possible to see more information (on the display).

## 10.2 Printerinterface / Print Manager

The printerinterface is needed for connecting a printer to the ETS by the parallel printer port. By the menu (see printing data from the ETS) it is possible to select a list for printing.

**Attention !** You need a DOS compatible printer.

Print Manager is a software for you PC. With Print Manager it is possible to read the hole contents of a clock (Speedy or little). After the read out it is possible to print the overview list training list, clocking and pigeon list on the windows based printer on the pc.

## 10.3 Modem / SMS interface

When a pigeon is clocked it is possible to send a SMS with the SMS interface. The SMS interface is a additional simbox connected to the clock.

### Setup :

Connect the clock to the antennas (no flight in the clock if you modify the settings !)

On the screen of the Little you see "SMS found" press "OK". The clock starts in training mode, got to the menu by pressing "C". Now press Menu and chose 3 options and again point 3 SMS you can change the setup.

1. Telephone number    Fill in the GSM number and also the code of the country  
for example 32475752175 (code of country followed by the  
telephone number without the 0)
  
2. Setup    **1. training** : No (sending training pigeons or not, push 1 to change)  
By setting the training on 'yes' , you get automatic setup, namely 4 by number and  
10 by group. It takes 30 sec. before the pigeon will be send. In case of the 30 sec.  
more pigeons arrive, they will send together.  
**2. number** : xx (the number of pigeons from who you want to receive a message,  
according to arrival) These messages will be send a few seconds after arrival.  
**3. Group** :xx (to give you a message when for example 10/20/30 pigeons are arrived/flight)  
**This setup must always be higher than the number.**
  
3. Test SMS    You can test the connection and a text will be send to a GSM that you chose.  
**Attention :** *how more SMS are sent how higher the GSM cost*

## 10.4 Emergency battery

This battery ensures that during flow discontinuances the network does not go down. You can clock with the ETS without problems.

The time which the electronic system remain operational without flow depends of the total flow usage of network. This is approximately 1.5 hour at a usage of 5A.





### **10.5 Antenna Buffers.**

Standard you can connect 16 antennas on the LITTLE BRICON 16.

If you need more than 16 antennas, you need antenna buffers.

On the antenna buffer it is possible to connect 16 antennas.

Maximum you can connect 16 buffers with 16 antennas on your electronic clocking system. (total 256 antennas). You need to program the buffers like a normal antenna. (ID must be unique)  
See 2.4 programming antennas page 6

## **11. Short working method**

At purchase of new ETS (clock) the antenna must be programmed first.

After that the installation must be assembled as discussed in the guide

You made a linking table (test linking), and you make a final test.

After the test flight you can take part of an official race.

The club sends the fancier details and the linking table to the clubmaster.

Now the pigeons can be basketed in the club.

The ETS of the fancier must be taken along for that.

The fancier gets a print-out with the basketed pigeons.

After basketing the fancier can connect his ETS to his antennas

The ETS starts in clocking mode and is ready to clock pigeons (after the release of the pigeons)

After clocking the BA can be brought back to the club.

There the flight is read out, and the fancier gets a print-out of the times.

At home you can print the list again with the USB Print Master

After that you can delete the released flights.

## **12. Problems and solutions**

### **12.1. Races can not be deleted.**

When a race has expired, but that flight is not read out in the club, you are not able to remove the flight on the BA. We must bring back the BA to the club to read out the race

### **12.2. Problems with the basketing of pigeons**

If the chip ring is not linked with a national foot ring, the clock will ask for an emergency link. It is always possible to change the emergency link.

### **12.3. There is nothing on the display of the Little**

Check the connection between the ETS and the antenna. Check the power supply

### **12.4. Pigeons are not clocked**

Check the connection between the ETS and the antenna.

Press "1" on the Little. The display shows the connected antennas.

Test the system with a training.



### **12.5. Antenna problems**

When the ETS detect a couple of antennas and one of the antennas fail, The ETS will sound an alarm. On the display you see ANTENNE ERROR.

Disconnect the power supply and check the cables and the antennas

After the reconnection of the power supply, the clock surge al connected antennas.

Check if the number is right.

### **12.6. Pigeons are not clocked.**

Look in this manual for optimal installation of the antennas.

The immediacy of other antennas or metal objects can also influence the good functioning of the antennas

### **12.7. No communication BRICON en BRICON+**

If the little BRICON shows a higher number of antennas on the display,

the reason is probably with the installation of the BRICON+. Disconnect the BRICON+

from the Little, connect first the BRICON+. After start up , you can connect the + to the clock

### **12.8. More antennas are connect then the Little shows.**

Look to the wiring after discontinuances and checks if there are no antennae with the same ID number

See test the antennas 2.6. on page 11 and program antennas 2.4 on page 6.

### **12.9. Extend the installation .**

By the extension of the electronic system (one or more antennas) You must take a look at to the total electricity consumption (see 10).

Check if you need more connection cables, splitters etc.

### **12.10. Printer doesn't print.**

Connect the printer on the proper way. Check if the printer is DOS compatible.

Is paper present in the machine ?

## **13. Maintenance and service.**

Always keep the Little BRICON clean and do not allow the clock to be immersed in water or other liquids. Remove dirt from the Little with a lightly dampened cloth and do not use solvents.

Should the Little clock need repair, this must by carried out by Bricon.



## 14. Overview menu

### 1. Clocking

### 3. Menu

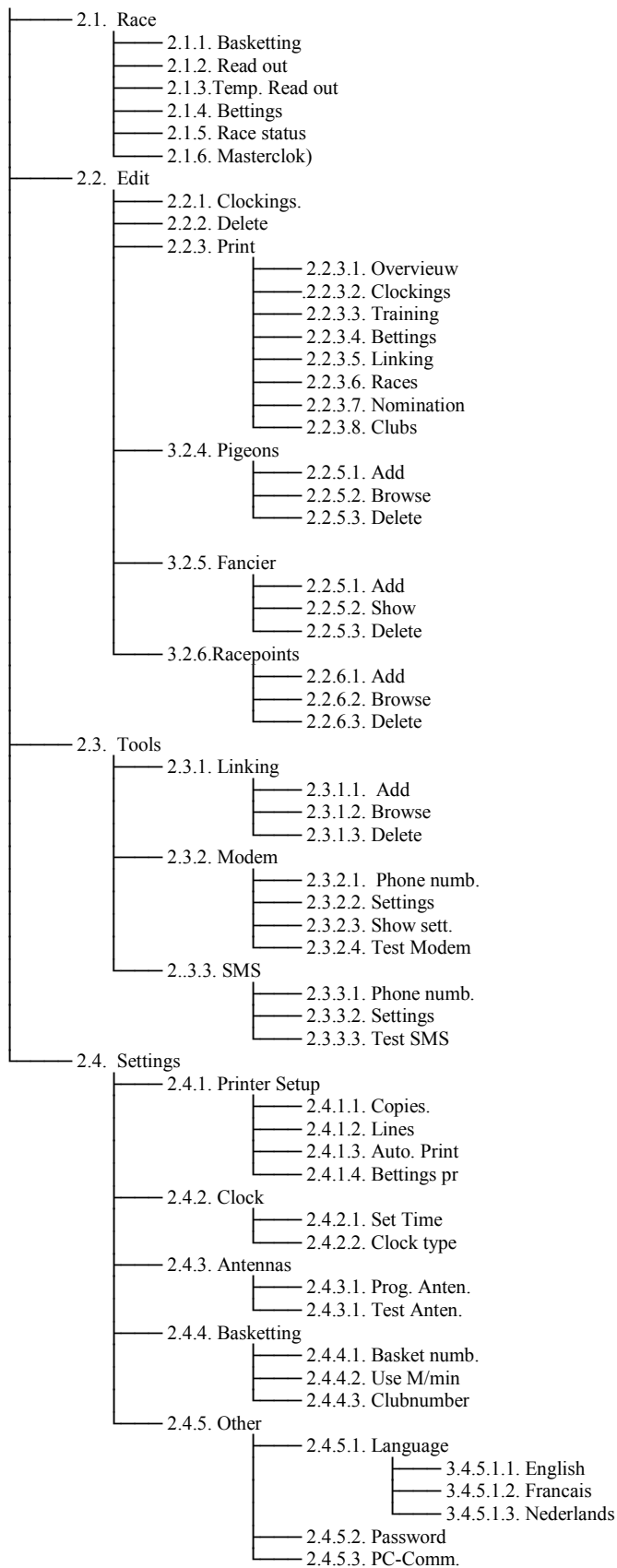



# Declaration of conformity

Directive 1999/5/EC (R&TTE)

**BRICON nv**  
Europark Oost 15 C,  
9100 Sint-Niklaas  
Belgium

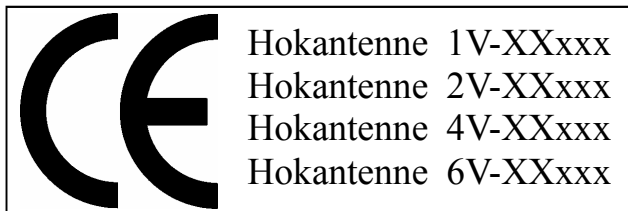

We declare the product mentioned below on which this declaration is related to that on own justification, in agreement is with the essential requirements and with other relevant provisions of the R&TTE directive (1999/5/EC).

Article :               Loft Antenna  
                          BRICON 1V(14cm), 2V(28cm), 4V(50cm), 6V(70cm).

Type :                 Reader for transponders (125kHz)

In agreement are with Â§3 of R&TTE- the directive.

Health and security Â§3 (1) a:

Used standard:

EN 60950:1992+A1+A2:1993+A3:1997+A11:1997

EMC §3(1)b:

Used standard:

EN 301 489-3/07.200

Radio frequency spectrum Â§3 (2)

Used standard:

EN 300 330-2 V1.1/7.2000

Technical file is available on the seat of the manufacturer.

BRICON nv, Europark Oost 15C, Sint-Niklaas, Belgium.

Place and date of expenditure: Sint-Niklaas, 13-12-2005.

Responsible for the manufacturer:

Ivan Baetens  
Delegated director.

Francis Nolmans  
Delegated director.

